

LUBRICATE ALL SEALS WITH CLEAN HYDRAULIC OIL PRIOR TO ASSEMBLY. DO NOT USE SILICONE BASED LUBRICANTS.

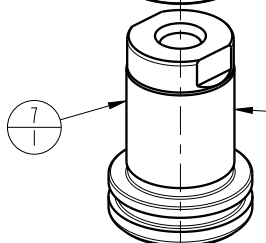

TIGHTEN TO 55 FT-LBS TORQUE  
USE VEKTEK TORQUE TOOL  
NEW STYLE TORQUE TOOL AT200151, 10 POINTED TOOL (CIRCA 2018)  
OLD STYLE TORQUE TOOL AT200150, 2 POINTED SPANNER HOLE TOOL



PISTON KIT INCLUDES PISTON AND RETAINING RING 23050013

INSTALL WITH LIPS DOWN



SPRING PAK  
REMOVAL - INSERT 1/8" INTERNAL HEX WRENCH THRU SAE 4 PORT INTO SPRING PAK RETAINER AND ROTATE CLOCKWISE AS VIEWED FROM BOTTOM. (REINSTALL- REVERSE ABOVE PROCEDURE)

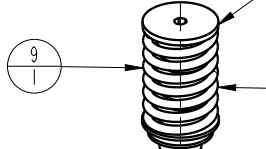

SPRING KIT 61200115  
INCLUDES  
SPRING PAC 92060003 AND BOTH RETAINING RINGS 23002003 & 23050013



RETAINING RING, 23002003 (NARROW GROOVE)  
OLD STYLE

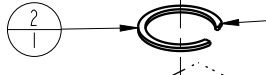

RETAINING RING, 23050013 (WIDE GROOVE)  
CURRENT STYLE, CIRCA 08/01/2003

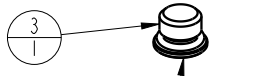
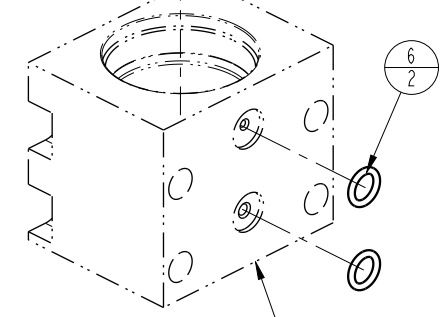

TIGHTEN TO 15 FT-LBS TORQUE

BODY, NOT A REPLACEMENT PART

N/A	N/A	61200115	KIT, SPRING	N/A	N/A	NOTED
N/A	N/A	6V210112	KIT, SEAL, FKM	N/A	NOTED	N/A
N/A	N/A	60210112	KIT, SEAL, STANDARD	NOTED	N/A	N/A
9	1	92060003	SPRING PAK, CYL, 8800, 0.5 STRK			X
8	1	82031501	GLAND, CYL, 8800 & 39.9 KN			
7	1	62201504	Kit, Piston, Ring & Tag, 8800, 0.5 STRK			
6	2	39050042	O-RING, (-011)	X	39051025	
5	1	39050020	WIPER, SNAP-IN, (1-1/8)	X	X	
4	1	39011028	SEAL, BEVEL, 1-5/16 X 3/32 X 1-1/2	X	39012015	
3	1	30601145	PLUG, SOCH, SAE 4, LOW HEAD			
2	1	23050013	SNAP RING, INTERNAL			X
1	1	23002003	SNAP RING, INTERNAL			X
No.	QTY	PART No.	DESCRIPTION	Standard Seal Kit	FKM Seal Kit	Spring Kit

### PARTS LIST



VEKTEK, INC.  
1334 E. SIXTH AVE. P.O. BOX 625  
EMPORIA, KS. 66801 U.S.A.

ASSEMBLIES AFFECTED  
21111500  
21111500F

PARTS LIST, ASSY, CYL, BB, MM, 8800, 0.5 STRK, SA

SIZE A  
PL2155

REV G

SHEET 1 OF 1

FORM FEG035\_PL\_ASIZE, REV. B

G	5499	RELEASE	NPETERS	9/23/24
REV	IN ACCORDANCE WITH ECN	EFFECTIVE DATE	REVISED BY	DATE
DRW BY:	JACOB	<b>DRAWING STATUS: Released</b>		
DATE:	05/08/97	PRODUCTION APPROVED FOR RELEASED STATUS ONLY		